

# USER GUIDE AND INSTALLATION MANUAL AIR COMMAND™ AIR8000/6000/4000/2000

London: +44 2070 9 98213 Australia: +61 3 9001 8624 New Zealand: +64 99849446 Mexico: +52 551 1638622 Japan: +81 345801938

Congratulations on your purchase of the **Air Command™** - the most advanced and easiest to use air bag control system on the market! With a backlit display, real-time control of all of your air bags, and up to 8 fully customizable presets, the **Air Command™** will put you in complete control of your air suspension system at the touch of a finger.

## FEATURES

**8 User-adjustable presets:** When selected it will automatically adjust the valves to the preset level.

There are four different Air Command models:

- AIR8000** allows 8 presets
- AIR6000** allows 6 presets
- AIR4000** allows 4 presets
- AIR2000** allows 2 preset

**Sensor Monitoring:** Real-time monitoring of up to 5 sensors (Left Front, Left Rear, Right Front, Right Rear, Tank)

**Auxiliary Inputs:** Allow control of the Air Command™ via third party controllers.

**Arm Mode:** When "Armed Input" wire senses a signal from alarm it will deactivate all features of the display and show a big bold "ARMED" message.

**Smart Buttons:** To increase or decrease ride height, press arrow keys.

- a. Press Once = Incremental Changes
- b. Press and Hold = Rapid incremental changes.

**Optional Input** for Auto Adjust Unit.

**Automatic Compressor Control:** When the tank reaches a user defined level it will send a negative output for the compressor to run. This signal will remain on until tank reaches user specified pressure level.

- i. For air compressors that draw less than 30amps,
  - ii. Connect red wire to a switch power source.
  - iii. Connect green wire to (+) wire on compressor.

For compressors that use more than 30amps or multiple compressors, see diagram below:

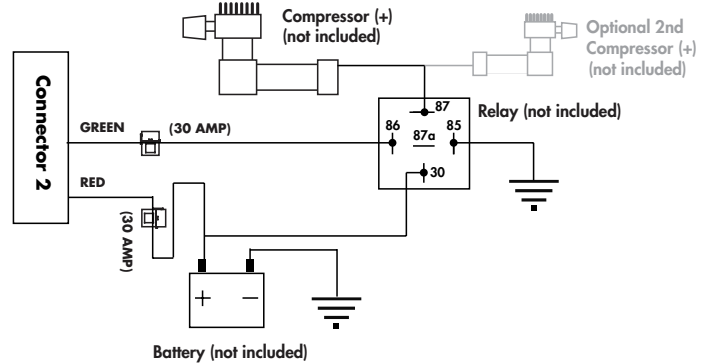

### I. Reconnect Negative Battery Terminal

M. Program the Sending Unit as follows:

### Controller Diagram

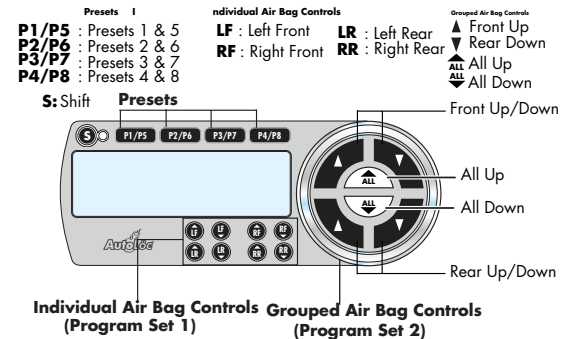

### 4 How to Calibrate the Sending Unit

1. Hook up an analog gauge to Tank.
2. Press and hold **S** and both **ALL** and **ALL** buttons at the same time, till shift LED starts to flash and Tank's air pressure shows "T000" on the LED, which means the unit, has entered into programming mode.
3. Inflate the tank to any air pressure. Read the air pressure on the analog gauge, and press both **ALL** and **ALL** buttons till Tank's air pressure shows the same on both the LCD and the analog gauge.
4. Press **S** button to program current resistance of the sending unit.
5. Repeat step 3 and 4 (until the unit knows at least 2 resistances (up to 16 can be programmed). The more resistances that are programmed the more accurate it will be.
6. Press **S** button to exit learning mode.

## Installation

For detailed instructions, see operations section

- 1 **⚠ Safety First!** Disconnect negative battery terminal
- 2 **Mount** Air Genie™ receiver and control display in a dry spot.
- 3 **Wire** according to diagram (fig 4 on page 4)
  - a. Connect red wire to 12v constant
  - b. Connect black wire to (-)ground
  - c. Connect yellow wire to (+) switched power ignition
  - d. Connect pump wires to corresponding valve's terminal 60 of activation relay.
  - e. Connect dump wires to corresponding valve's terminal 60 of activation relay.
  - f. Connect sending unit wires to (-) output of pressure sensor
  - g. *Optional* - If using keyless entry use (-) outputs to trigger manual valve or preset wires in connector 1.
  - h. *Optional* - Connect grey wire connector 1 to a (-) output of keyless entry or alarm to disable unit when armed.

# USER GUIDE AND INSTALLATION MANUAL

## AIR COMMAND™ AIR8000/6000/4000/2000

**N. Program** valve timing and settings according to steps below:

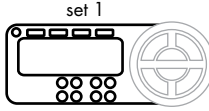

### 5 Valve Timing and Settings (Program Set 1)

1. Press **LF** **LR** buttons at the same time for 10 seconds until the shift LED starts to flash.
  - a. The number shown on the LF LCD represents the output time (10=1sec. 0=0sec. the default is 5=0.5sec), press **LF** **LR** buttons to adjust. The number shown on the RF LCD represents the output interval (10=1sec. 0=0sec. the default is 5=0.5sec), press **RF** **RR** buttons to adjust. The number shown on LR represents the air pressure tolerance (the default is 5psi), press **LR** **RR** buttons to adjust. The number shown on RR represents auto-cycling on/off value.

- b. Press **S** button to exit.

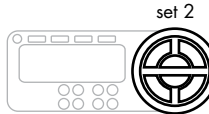

### Valve Timing and Settings (Program Set 2)

1. Press **RF** **RR** buttons at the same time for 10 sec., till shift LED starts to flash
  - a. The number shown on LF of the LCD represents the output time (10=1sec. 0=0sec. the default is 5=0.5sec), press **LF** **LR** buttons to adjust. The number shown on RF of LCD represents the output interval (10=1sec. 0=0sec. the default is 5=0.5sec), press **RF** **RR** buttons to adjust.
- b. Press **S** button to exit

## Operations

### How to Set Preset

1. Adjust each air bag to the desired pressure.  
For preset **P1, P2, P3, P4**
2. Press and hold selected preset button for 7 seconds.  
For preset **P5, P6, P7, P8**
  - a. Press the **S** button
  - b. Press and hold selected preset button for 7 seconds.
3. System will flash to confirm

### How Set Compressor Tank Pressure

(Default Setting 110psi)

1. Press and hold both **ALL** and **ALL** buttons for 5 seconds  
Seconds. (Tank section of LED Display should be Blinking)
2. Use the **ALL** and **ALL** buttons to choose the desired pressure.
3. Press and hold both **ALL** and **ALL** buttons for 5  
Seconds. (Tank section of LED Display should STOP Blinking)

**User Reset:** Resets the Air Command to factory defaults.

1. Press and hold ALL FOUR Preset buttons for 10 seconds (Shift light will go on)
2. Press the **P2/P6** button (shift light will blink)
3. Press the **P4/P8** button (shift light will stop blinking)

## Wire Descriptions

### CONNECTOR 1 :: 3rd Party User Interface :: Optional

Pin 1 :: Yellow/ Black :: Negative (-) Input :: Preset 2 Activation  
:: This wire will activate your Preset 2 when given a negative ground signal.

Pin 2 :: Brown :: Negative (-) Input :: Preset 1 Activation :: This wire will activate your Preset 1 when given a negative ground signal.

Pin 2 :: Blue :: Negative (-) Input :: Preset 3 Activation :: This wire will activate your Preset 3 when given a negative ground signal.

Pin 4 :: Yellow :: Ignition Positive (+) Input :: This wire activates the illumination on the display when given 12 volts positive.

Pin 5 :: Purple :: Negative (-) Input :: Preset 4 Activation :: This wire will activate your Preset 4 when given a negative ground signal.

Pin 6 :: Grey :: Negative (-) Input :: Alarm Wire :: This wire will activate the alarm mode when given an constant negative ground.

Pin 7 :: Green / Black :: Negative (-) Input :: Preset 5 Activation  
:: This wire will activate your Preset 5 when given a negative ground signal.

Pin 8 :: Red :: Negative (-) Input :: Preset 6 Activation :: This wire will activate your Preset 6 when given a negative ground signal.

Pin 9 :: Pink :: Negative (-) Input :: Preset 7 Activation :: This wire will activate your Preset 7 when given a negative ground signal.

Pin 10 :: Orange :: Negative (-) Input :: Preset 10 Activation  
:: This wire will activate your Preset 10 when given a negative ground signal.

Pin 11 :: Green :: Negative (-) Input :: Right Rear Pump :: This wire will activate your Right Rear Pump Valve when given a negative ground signal.

Pin 12 :: Brown / White :: Negative (-) Input :: Right Rear Dump  
:: This wire will activate your Right Rear Dump Valve when given a negative ground signal.

Pin 13 :: Purple / Black :: Negative (-) Input :: Light Rear Pump :: This wire will activate your Light Rear Pump Valve when given a negative ground signal.

Pin 14 :: Red / Black :: Negative (-) Input :: Left Rear Dump :: This wire will activate your Left Rear Dump Valve when given a negative ground signal.

Pin 15 :: Grey / Red :: Negative (-) Input :: Right Front Pump :: This wire will activate your Right Front Pump Valve when given a negative ground signal.

Pin 16 :: Orange / Black :: Negative (-) Input :: Right Front Dump  
:: This wire will activate your Right Front Dump Valve when given a negative ground signal.

Pin 17 :: Pink / Black :: Negative (-) Input :: Left Front Pump :: This wire will activate your Left Front Pump Valve when given a negative ground signal.

Pin 18 :: Yellow / White :: Negative (-) Input :: Left Front Dump :: This wire will activate your Left Front Dump Valve when given a negative ground signal.

### Connector 2 :: Power & Valve Outputs ::

Pin 1 :: Red :: 12 Volt Power Supply :: This wire is the main feed into the unit and needs to be connected to a fused 12 volt constant power supply.

Pin 2 :: Black :: Chassis Ground :: This wire is the main ground into the unit and needs to be connected to a fused 12 volt constant power supply.

Pin 3 :: Purple :: Positive (+) Output :: Left Rear Pump :: This wire will activate your Left Rear Pump Valve relay when given a negative ground signal.

Pin 4 :: Grey :: Positive (+) Output :: Right Front Pump :: This wire will activate your Right Front Pump Valve relay when given a negative ground signal.

Pin 5 :: Green :: Positive (+) Output :: Right Rear Pump :: This wire will activate your Right Rear Pump Valve relay when given a negative ground signal.

Pin 6 :: Brown :: Positive (+) Output :: Right Rear Dump :: This wire will activate your Right Rear Dump Valve relay when given a negative ground signal.

Pin 7 :: Yellow :: Positive (+) Output :: Left Rear Dump :: This wire will activate your Left Rear Dump Valve relay when given a negative ground signal.

Pin 8 :: Blue :: Positive (+) Output :: Left Front Dump :: This wire will activate your Left Front Dump Valve relay when given a negative ground signal.

Pin 9 :: Orange :: Positive (+) Output :: Right Front Dump :: This wire will activate your Right Front Dump Valve relay when given a negative ground signal.

Pin 10 :: Pink :: Positive (+) Output :: Left Front Pump :: This wire will activate your Left Front Pump Valve relay when given a negative ground signal.

### Connector 3 :: Sensor Input ::

Please note the sensor needs to be grounded good. Poor display readings is caused by bad sensor grounds, or incorrect sensor learning. In addition you must use the same style sensor for all Bags and tanks.

Pin 1 :: Red/White :: Tank Sensor Input (variable negative resistance) :: This wire hooks up to a sensor w/ a linear negative resistance variable. Use Hoffman Group part # AIRSENSOR.

Pin 2 :: Brown/Blue :: Left Front Bag Sensor Input (variable negative resistance) :: This wire hooks up to a sensor w/ a linear negative resistance variable. Use Hoffman Group part # AIRSENSOR.

Pin 3 :: Orange/Blue :: Right Front Bag Sensor Input (variable negative resistance) :: This wire hooks up to a sensor w/ a linear negative resistance variable. Use Hoffman Group part # AIRSENSOR.

Pin 4 :: Blue/White :: Left Rear Bag Sensor Input (variable negative resistance) :: This wire hooks up to a sensor w/ a linear negative resistance variable. Use Hoffman Group part # AIRSENSOR.

Pin 5 :: Orange/Green :: Left Rear Bag Sensor Input (variable negative resistance) :: This wire hooks up to a sensor w/ a linear negative resistance variable. Use Hoffman Group part # AIRSENSOR.

## Troubleshooting

- Q.** When I press my preset button the system has a hard time finding the preset accurately.
- A.** If the system can't find your preset easily you will need to adjust the interval time which can be set between 1-10, 1 being 1/10 of 1 second, 10 being 1 full second.
- Q.** Display is reading inaccurate PSI.
- A1.** If the PSI reading is incorrect you will need to re-calibrate your sensors to the air command system.
- A2.** Confirm the sensors are grounded.
- A3.** Maximum PSI of sensor has been exceeded.
- A4.** The sensor is a non-linear sensor and is not compatible with the Air Command.
- Q.** Display shows alarm and nothing works.
- A.** Deactivate your alarm system.
- Q.** Display will not illuminate. (nothing on screen)
- A.** Be sure that the solid yellow wire is hooked up to switched ignition power.
- Q.** Cannot program presets 5, 6, 7, 8
- A.** Presets 5 through 8 are available only on the AIR8000. If you have purchased an AIR8000, make sure that you're pressing the shift button and that the red LED is illuminated.

# USER GUIDE AND INSTALLATION MANUAL

## AIR COMMAND™ AIR8000/6000/4000/2000

**IMPORTANT:**  
Use KeepItClean™  
part# RELAY

### Left Front Diagram:

Pressure Sending Unit

Ground Sending Unit or Air Command™ will not work.

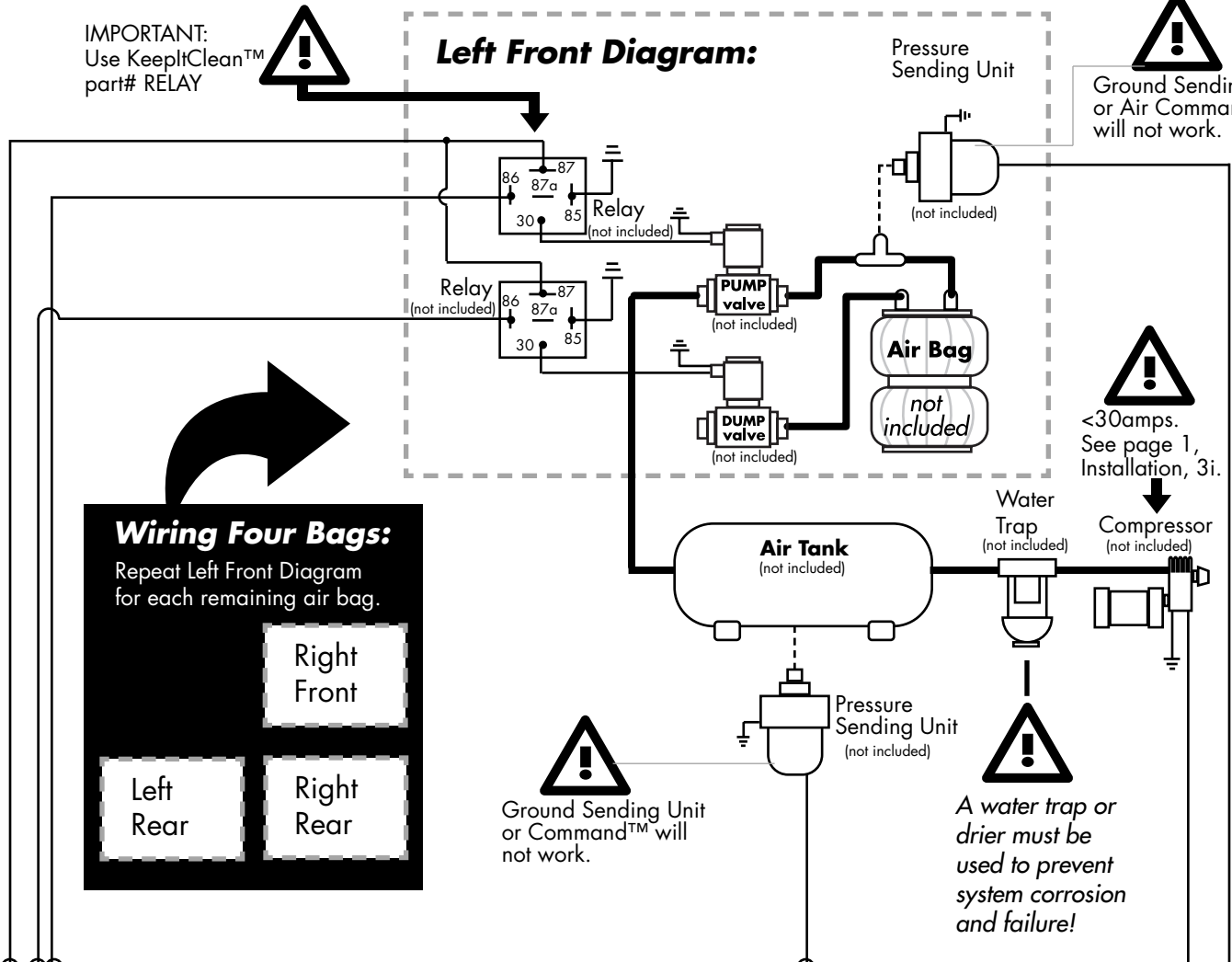

- YELLOW/BLACK PRET2
- BROWN PRET1
- BLUE PRET3
- YELLOW IGN
- PURPLE PRET4
- GREY ALARM-IN
- Green/Black PRET5
- RED PRET6
- PINK PRET7
- ORANGE PRET8
- GREEN M-RR-PUMP
- BROWN/WHITE M-RR-DUMP
- PURPLE/BLACK M-LR-PUMP
- RED/BLACK M-LR-DUMP
- GREY/RED M-RF-PUMP
- ORANGE/BLACK M-RF-DUMP
- PINK/BLACK M-LF-PUMP
- YELLOW/WHITE M-LF-DUMP

- RED FUSE 30A
- GREEN FUSE 10A
- RED +12V
- BLACK GND
- PURPLE LR-PUMP
- GREY RF-PUMP
- GREEN RR-PUMP
- BROWN RR-DUMP
- YELLOW LR-DUMP
- BLUE LF-DUMP
- ORANGE RF-DUMP
- PINK LF-PUMP

